

NMEA2000® Digital Tank Level Gauge



- Available for Fuel, Fresh Water, and Black Water
- Automatic low and high level alarms
- Standard 2" Panel Gauge Size
- 10A changeover relay contacts for external alarm or device control
- Display varies in brightness to suit ambient light level
- Front and Panel Sealed to IP66
- NMEA2000® network standard

The 3350 Digital Tank Level Gauge displays the Fuel, Fresh Water or Black Water tank level digitally on a standard 2" Panel Gauge.

It includes an automatic high and low level alarm that operates a sounder and a flashing red LED when the level passes user settable limits. The sounder can be muted from the front panel.

The 3350 is fitted with a 10 amp relay that can control an external alarm or device that is set when the unit triggers it's high or low level alarm level. The unit mounts in a standard 2" diameter panel hole and the front and panel seal is to IP66.

It has a blue LED digital tank level display that varies in brightness as the ambient light level varies.

It is manufactured to the NMEA2000® network standard and attaches to the network using a single "Micro" plug. It draws less than 150mA from the network.

NMEA2000® Digital Tank Level Gauge

Part No: 3350-F, 3350-W and 3350-B

Dimensions

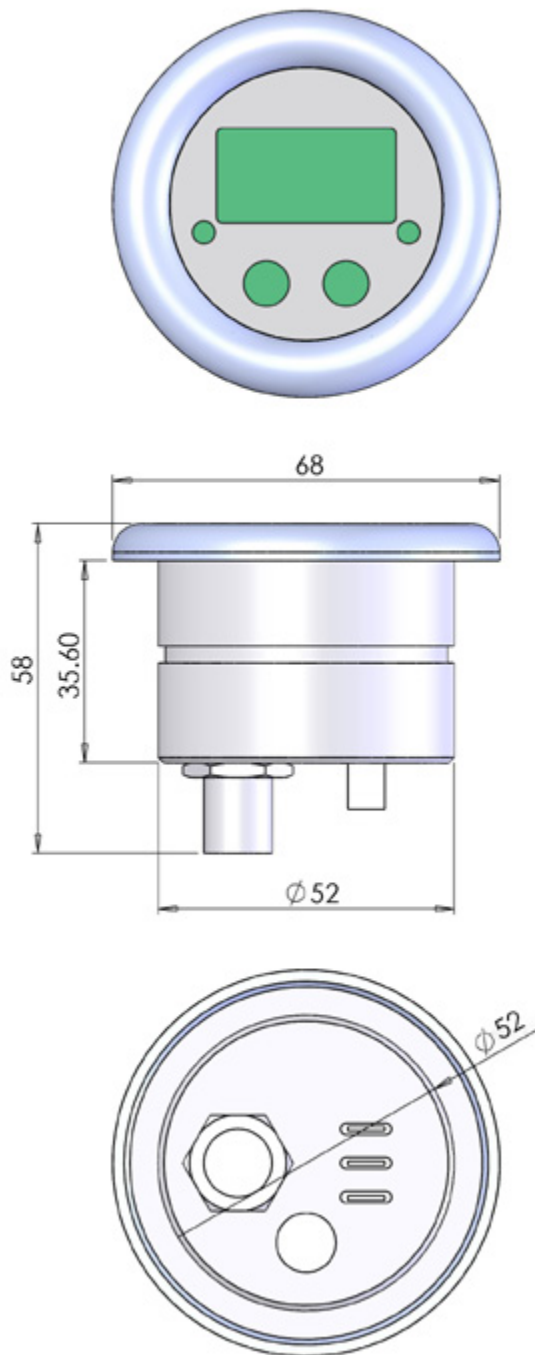

Specification	
Accuracy	Display to 1%
LED Display	Dims to ambient light level
Design Standards	
NMEA2000®	Level B+
Maritime Navigation and Radiocommunication Equipment	IEC 60945
CE Mark and FCC	Electromagnetic Compatibility
NMEA2000® PGNs	
Periodic	PGN127505 Fluid Level
Requested	PGN126996 Product Info
Protocol	PGN059392 ISO Acknowledge PGN059904 ISO Request PGN060928 ISO Address Claim PGN065240 ISO Address Cmd PGN126208 Complex Request
Electrical	
Operating Voltage	9 - 30 Volts DC
Power Consumption	<150mA
Load Equivalence	3 LEN
Relay	10 Amp Changeover
Reverse Battery	Protected
Load Dump	Protected
Mechanical	
Body Size	68mm Diameter 60mm Deep
Rear Clearance	Allow 100 for cable connection
Weight	Approx 130 gms
Panel Mounting	Standard 52mm / 2" Hole in Panel 1-25mm thick
Environmental	
IEC 60945 Classification	Exposed
Protection	IP66
Operating Temperature	-25C to +55C
Storage Temperature	-40C to +70C
Relative Humidity	93%RH@40C per IEC60945-8.2
Corrosion - Salt mist	As per IEC 60945-8.12
Electromagnetic Emission	Conducted and Radiated as per IEC 60945-9
Electromagnetic Immunity	Conducted, Radiated, Supply and ESD per IEC 60945-10